

H190-360HD²SERIES



**STRONG PARTNERS.
TOUGH TRUCKS.™**

HEAVY DUTY FORKLIFT TRUCK



H190-360HD₂ SERIES

CAPABLE TRUCKS FOR HEAVY DUTY APPLICATIONS

The Hyster® H190-360HD₂ series is an exciting enhancement to the heart of the big truck product line. These trucks have been developed, tested extensively and refined to provide outstanding performance in lumber, concrete, steel, oil & gas, produce and other heavy duty industries and applications.

The Tier 4 Final powertrain features an emission reduction package that includes cooled exhaust gas recirculation (EGR), a selective catalytic reduction (SCR) system for nitrogen oxide (NOx) reduction, a diesel oxidation catalyst (DOC) for particulate matter removal and a diesel exhaust fluid (DEF) delivery system. These efficient features deliver up to 20% lower fuel consumption over Tier 3 products.

Several models are available to choose from, including three most recent 48" load center models: the H210-48HD truck with 21,000 lbs. of lifting capacity, H230-48HD truck with 23,000 lbs. capacity, and the H250-48HD truck with 25,000 lbs. of lifting capacity. Also available with the Tier 4 Final offering are two compact, heavy duty lift trucks: the H300HD₂S with 30,000 lbs. and the H330HD₂S with 33,000 lbs. lifting capacity, both featuring a short 114" wheelbase at a 24" load center*. Suited for applications where compactness and high maneuverability are vital, these models round out the Hyster offering of both short wheelbase 24" load center trucks and standard wheelbase 48" load center trucks in addition to 24" load center trucks in the 19,000 through 36,000 capacity range.



** The Hyster® H300HD₂S and H330HD₂S models are available via SPED featuring a standard Cummins 6.7L QSB engine.*



■ **DEPENDABILITY**

- Rigid mast and front end design
- Carriage and fork options
- Powertrain features
- Cooling package
- Greaseable load rollers

■ **LOW COST OF OWNERSHIP**

- Integrated systems design
- On-demand cooling
- On-demand hydraulics
- Traction speed limiter
- Auto-throttle up
- Lower fuel consumption

■ **SERVICEABILITY**

- Quick access to key components
- On-board diagnostics
- Longer service intervals
- Cooling system
- Guaranteed Availability Program (G.A.P.)

■ **ERGONOMICS**

- Visibility
- Cab Comfort
- Low Noise
- Proportional hydraulic control

■ **PRODUCTIVITY**

- Rated capacities
- Lift, lower and travel speeds
- Auto-shift transmission with true inching
- Heavy duty, compact footprint
- Hyster Tracker compatible

DEPENDABILITY

■ RIGID MAST AND FRONT END DESIGN

Over 80 years of Hyster expertise in mast and carriage design is brought to bear with mast channels, rollers, stubshafts and chain anchors designed for heavy duty applications. Robust mast design for the 19,000 through 36,000 lbs. range incorporates decreased mast deflection and increased stiffness than comparable competitors' masts with overhead tilt.

Two-stage masts designed for both pin type and apron style carriage mounting options with individual and simultaneous fork positioning are available for the H190-360HD₂ series. Greaseable load rollers and bearings help to ensure that the front end provides years of dependable performance. Carriages are designed to have full rated capacity with standard pin type carriages while realizing minimum capacity derate on sideshifting carriages so the truck can provide maximum performance under heavy duty operating conditions.

■ CARRIAGE & FORK OPTIONS

- Standard pin type carriage with mechanical fork locks
- Pin type with individual hydraulic fork positioning
- Apron-style sideshift
- Apron-style sideshift with either simultaneous or individual fork positioning
- Dual function sideshift fork positioner
- Less carriage options with provision for base carriages enabling 3rd-party supplier attachments

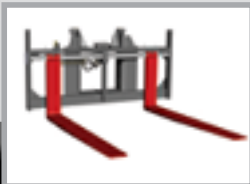

Standard Pin Type carriage with mechanical fork locks

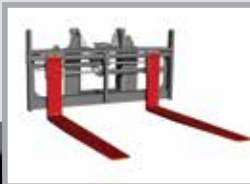

Standard Pin Type Carriage with Fork Positioning



Dual Function Sideshift Fork Positioning Carriage



Apron Style Carriage with Fork Positioning



Apron Style Sideshift Carriage

■ HEAVY DUTY DRIVE AXLE

A robust AxleTech PRC 485 drive axle with wet disc brakes provides enhanced performance in rugged operating conditions and longer service intervals on fluid changes. In the H190-280HD₂ models, this drive axle design provides a 36% improvement in spindle strength and a 6% improvement in wheel end torque capacity over previous models. In the H300-360HD₂ and H210-250/48HD models, the drive axle design provides a 22% improvement in spindle strength and a 10% improvement in wheel end torque capacity over previous models.



■ POWERTRAIN

The Tier 4 Final solution features a well-integrated drivetrain that includes an after-treatment emission reduction package featuring cooled exhaust gas recirculation (EGR), a selective catalytic reduction (SCR) system for NO_x reduction, a diesel oxidation catalyst (DOC) for particulate matter (PM) removal and a diesel exhaust fluid (DEF) delivery system. The ZF WG-161 3-speed transmission features improved shift point selection enabling optimal efficiency of the drivetrain while limiting fuel consumption. Two engine options are available:

1. Cummins QSB 4.5L engine with a turbocharger and exhaust gas recirculation for the H190-280HD₂ trucks.
2. Cummins QSB 6.7L engine with high pressure common rail injection and exhaust gas recirculation in the H300-360HD₂ as well as the new 48" load center H210-48HD through H250-48HD models. This engine is also standard in the H300HD₂S and H330HD₂S short wheel base trucks.

Both engines feature powertrain protection systems to help reduce excessive temperatures and pressures. Torque derate strategy is implemented for engine and drivetrain protection. Powertrain derate helps to prevent damage to engine and transmission while enhancing component life by minimizing thermal degradation of engine oil, coolant and transmission fluids.

Torque derate conditions are activated on:

- high air intake temperatures
- high coolant temperature
- high transmission oil temperature
- low oil pressure

■ GREASEABLE LOAD ROLLERS

Greaseable load roller bearing and stub shafts are standard on all Hyster® H190-360HD₂ series trucks.

- Greaseable design allows bearings to be lubricated, removing wear particles from the roller body and reducing roller bearing failures
- Double row cylindrical bearing profile provides enhanced load distribution, resulting in longer bearing life for 19,000 to 28,000 lbs. and 30,000 to 36,000 lbs. trucks
- Greaseable bearings on H190-280HD₂ offer increased load capacity:
 - * +46% increase in dynamic load capacity
 - * +123% increase in static load capacity
- Greaseable bearings on the H300-360HD₂ and H300-360HD₂ and H210-250HD/48 offer increased load capacity:
 - * +37% increase in dynamic load capacity
 - * +133% increase in static load capacity
- Simplified installation and load roller assembly
- Access hole on masts to enable greasing of inner mast channel load roller bearings enhances ease of serviceability



Greaseable load roller bearings

■ ROBUST COOLING SYSTEM

- High capacity cooling system is designed for high temperature ambient conditions up to 113°F (45°C)
- Components last longer with cooler fluid temperatures
- Pusher fan drawing in cool and clean air enables the cooling system to operate more efficiently
- On-demand hydraulics reduces heat load into the truck by pumping oil only when needed.

The drivetrain runs cooler, thereby extending the hydraulic oil and component life. The robust cooling system runs cooler and lasts longer since the entire drivetrain runs more efficiently.



LOW COST OF OWNERSHIP

MORE VALUE FOR LESS COST

Hyster understands that your total cost of ownership extends beyond the initial acquisition costs. Hyster has collaborated with leading quality suppliers to provide well-integrated systems that help reduce your overall cost of operations over the useful life of the truck.

■ INTEGRATED SYSTEMS DESIGN

Both the Tier 4 Cummins QSB 6.7L engine and the QSB 4.5L engine are paired with the ZF WG-161 transmission. The Cummins QSB 6.7L engine is available as part of an optional Tier 3 package on all H190-360HD₂ series trucks except the short wheel base H300HD₂S and H330HD₂S models.

- Powertrain solution is optimized for maximum performance.
- Low emissions results in lower fuel consumption.
- Low-hassle Tier 4 Final solution requires no use of diesel particulate filter (DPF) or active regeneration. Utilizes diesel exhaust fluid (DEF), also known as urea, with a diluter for lower exhaust temperatures.
- A Tier 3 solution continues to be available in all non-EPA regulated markets.
- Innovative ECO modes
 - Hi-P provides maximum performance and good fuel economy.
 - ECO e-Lo provides minimum fuel consumption without losing productivity.



Integrated powertrain design

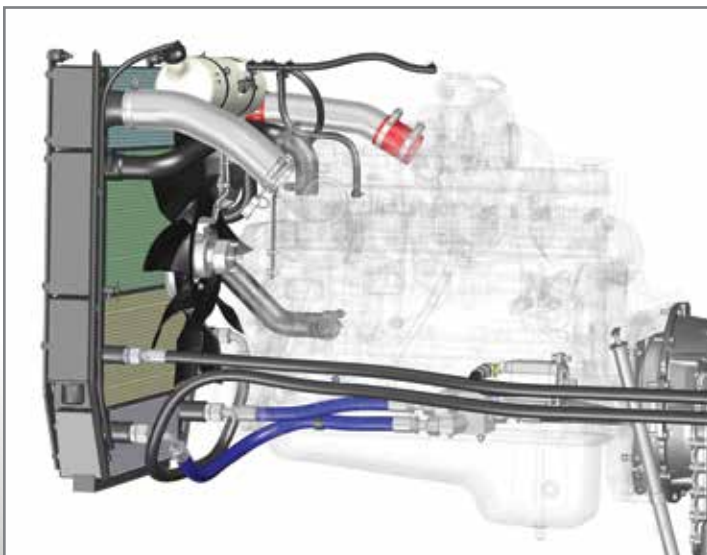

■ ON-DEMAND COOLING

- Features proportional viscous cooling fan which draws power only when cooling is required between 10% and 100% of the engine speed, unlike direct drive fans which draw high levels of power at all times.
- Reduces accessory loads on the powertrain, consumes less fuel and lowers noise levels.

■ ON-DEMAND HYDRAULICS

The Hyster® load sensing hydraulic system is designed to deliver flow only when required. A variable displacement pump, capable of more oil displacement even at low pump speeds, means the engine runs at lower speeds, extending the life of components while operating more quietly. The system consumes up to 10% less fuel than a typical fixed displacement hydraulic system while producing less heat. Oil and filters last longer; hoses, seals and components also wear less and last longer.

■ EMPTY SEAT ENGINE SHUTDOWN

This optional feature reduces fuel consumption by shutting down the truck when the operator is out of the seat for extended periods of time, thus limiting idle hours on the truck. Empty seat engine shutdown is programmable to activate within a 3-15 minute window after an operator leaves the seat. Factory preset to 15 minutes, the setting is easily adjustable by the customer with minimal tools, lowering the total cost of ownership over the useful life of the truck.

■ LOWER FUEL CONSUMPTION

Fuel consumption is a key driver of the total cost of ownership for heavy duty lift trucks. Hyster has collaborated with suppliers to provide comparable fuel consumption characteristics compared to similarly sized competitors' trucks.

The engine design produces more power and torque using XPI high-pressure common rail fuel injection and variable geometry turbochargers. Advanced controls enable the engine to provide peak performance and operating efficiency while delivering great fuel economy and durability.

■ AUTOMATIC THROTTLE-UP

Automatic throttle-up provides automatic response to lift inputs from the operator when the lift lever or joystick is activated while the truck is in neutral. A single-touch lever or joystick-controlled rev-up keeps the engine in the most efficient range, delivering good fuel economy.

■ TRACTION SPEED LIMITER

This optional feature reduces traction speeds and can be pre-set to suit varying customer applications:

- Unconditional traction speed limiter. Factory pre-set to 10 mph.*
- Loaded traction speed limiter – limits traction speeds to a set point when a specified load weight is sensed on the forks. Factory pre-set to 10 mph and activates at 10% rated load.

This system helps drivers to operate the truck in an optimal manner with regard to site limitations. Traction speed limiter settings are adjustable by your Hyster® dealer.

** Less speed means lower fuel consumption.*

Hyster Company Fuel Economy Estimates

Hyster® H190-360HD₂ Series

Fixed Displacement
Hydraulic System

9,000
GAL/YR

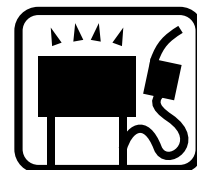

On-Demand
Hydraulic System

8,100
GAL/YR

Estimates Annual Fuel Savings

SAVE \$2,250 per year*

Typical 3000 hrs/yr with Hyster On-Demand
Hydraulic System and \$2.50/gal Fuel Price

** Based on fuel consumption savings from Tier 4 Final product validation testing.*

SERVICEABILITY

EASE OF SERVICE

Hyster® trucks have been designed with the service technician in mind. Gull wing hoods provide quick access to key components, and daily checks don't require tilting the cab. The engine and drivetrain are inclined at a two degree angle and are slightly raised, providing improved access to key components such as the alternator and hydraulic pump. A tilting cab provides easy access to hydraulic components in seconds. Galvanized, broad, slip-resistant running boards foster quick daily checks, while a large access bay enables easy radiator cleaning. A hydraulic sight gauge makes at-a-glance fluid level checks easier.

■ ON-BOARD DIAGNOSTICS

CANbus on-board diagnostics in an automotive-style layout with fuses centrally located on the side console provide easy servicing and troubleshooting. Error codes are provided on an LCD display for quick and effective identification of service items while enabling rapid implementation of remedies, reducing downtime and reducing the mean time for repairs.

■ LONGER SERVICE INTERVALS

Major engine and drivetrain components are engineered to operate on 500-hour service intervals. Hydraulic oil changes occur every 3,000 hours, and up to 6,000 hours with hydraulic fluid sampling, help to ensure that the truck remains in operation with longer mean times between oil changes or servicing, thus decreasing downtime and boosting machine productivity.

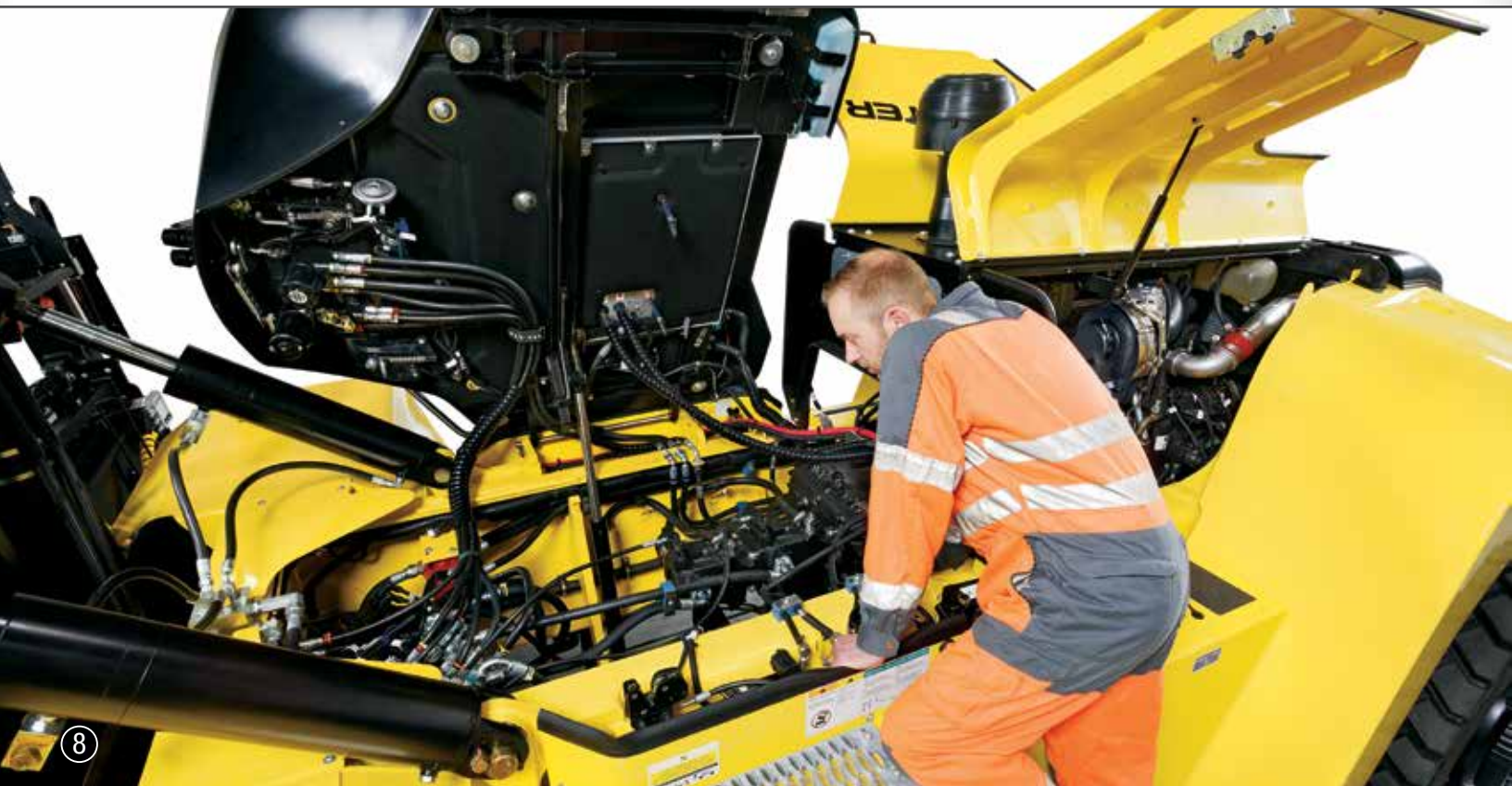

■ COOLING SYSTEM

- Designed for heavy duty cooling applications requiring additional cooling capacity
- Cooling cores are packaged such that cool air (not pre-heated air) is channeled across cores
- Quad-cooler radiator features four separate cooler cores
- Cool overhead air is drawn in for more efficient cooling than in stacked radiator configurations
- Louvered cooling fins for maximum air flow to radiator
- Hinged hood pivots at wide angles to provide easy access to cooling system
- Ample space in front of cooler cores enables effective maneuvering of service tools and equipment during service checks
- Easy to clean since coolers are not stacked in front of each other

The hinged hood enables easy serviceability access to the cooling system

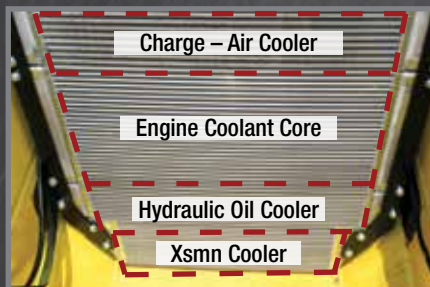

Quad-core configuration enables efficient cooling



■ SUPPORTING CUSTOMERS WITH WORLD-CLASS PARTS & SERVICE

Four Parts Distribution Centers strategically located around the world provide a full range of original equipment and aftermarket parts that help maintain our customers' uptime. In fact, our Guaranteed Availability Program ensures that parts that are normally required in the first 2 years of operation will be available from your Hyster® parts dealer within 24 hours or they are free.*



We also take that commitment into the field with the Hyster CERTECH® Certification training program. This technical training program provides both systems level as well as product-specific education to ensure lift trucks are repaired right the first time.

** Contact your local dealer for program details.*

ERGONOMICS

DESIGNED FOR OPERATOR COMFORT

As in all Hyster® big trucks, operator controls are conveniently placed within a spacious cab for maximum comfort to increase operator productivity.

■ VISIBILITY

A low profile carriage and the carefully positioned hydraulic valves, hosing and mast cross-members enable a clear view of fork tips. Canted hoses are arranged along the line of sight so the operator sees only one hose and has good visibility. A curved, shatter-resistant, tempered glass windshield provides an expansive front end view. Likewise, a curved rear windshield provides rearward visibility over the operator's left and right shoulders. On the exterior, sloping counterweights enhance visibility of steer tires for improved maneuverability and reduced tire gouging.

■ CAB COMFORT

The optional enclosed ComforCab™ II is mounted on elastomeric rubber mounts, isolating and minimizing the effects of road-borne shocks and vibrations. Its uncluttered, spacious floor is covered with a high-density rubber mat, which helps to decrease exterior sound to an amazingly low 76 dB(A) level. That's slightly less than the average sound level of music playing in your living room.

A tilting, telescoping steering column and an adjustable full-suspension seat keep the operator comfortable. The right-side armrest adjusts to position the truck's controls within easy reach. Mini-levers or joysticks and switches are integrated into the armrest for smooth controlled actuation of mast and attachment functions. The armrest also moves with the seat to maintain the driver's control of the truck even when driving over bumpy surfaces. Low effort, load-sensing power steering is standard equipment.





■ **LOW NOISE – OPERATOR & ENVIRONMENT**

With minimal noise at the operator's ear (72.8 dB(A) BITA), cabin interior noise ranks among the lowest in the industry, which enhances operator alertness and productivity. Lower engine speeds due to on-demand hydraulics, in tandem with the curved, tempered glass surrounding the cabin, results in quieter operation.



DEF level gauge is now standard.

■ **PROPORTIONAL HYDRAULIC CONTROL**

Proportional truck function settings can be adjusted to suit operator preferences. The automatic throttle-up function is enabled with a single touch actuation.

ENHANCED PRODUCTIVITY

MORE LOADS MOVED PER HOUR

■ RATED CAPACITIES

Hyster® H190-360HD₂ trucks offer full rated capacities at required load centers, and are engineered to ensure minimal derate compared to competitors' models.

- Full rated capacity up to 28,000 lbs. with a pin carriage on the H190-280HD₂ series
- Full rated capacity up to 36,000 lbs. with a pin carriage on the H300-360HD₂ series
- Full rated capacity up to 25,000 lbs. with a pin carriage on the H210-250/48HD series
- Very minimal derate for apron sideshift carriages
- Minimal derate (1000 lbs.) for DFSSFP carriages

■ LIFT, LOWERING & TRAVEL SPEEDS

Hyster® H190-280HD₂ trucks deliver high productivity with a 4-mode average speed of 90.0 ft/min (0.46 m/s). The Hyster® H300-360HD₂ and H210-250/48HD series also deliver high levels of productivity with 4-mode average speeds of 86 ft/min (0.44 m/s). Both rated capacities are very competitive in the heavy duty forklift industry.

Travel Speeds:

H190-280HD₂: 19 mph (30 km/h) with or without load

H300-360HD₂: 16 mph (26 km/h) with or without load

H210-250/48HD: 16 mph (26 km/h) with or without load

Lifting Speeds:

H190-280HD₂: 79 ft/min (0.40 m/s) with load / 89 ft/min (0.45 m/s) without load

H300-360HD₂: 71 ft/min (0.36 m/s) with load / 81 ft/min (0.41 m/s) without load

H210-250/48HD: 71 ft/min (0.36 m/s) with load / 81 ft/min (0.41 m/s) without load

Lowering Speeds:

All capacities: 98 ft/min (0.50 m/s) with load / 94 ft/min (0.48 m/s) without load

■ AUTO-SHIFTING TRANSMISSION WITH TRUE INCHING

These trucks are equipped with proven and reliable ZF 3-speed auto-shift transmissions paired with Cummins engines to provide true inching capability and not declutch like some of the competitors' trucks. The auto-shift transmissions enable smooth shifts that enhance the longevity of the drivetrain and operator comfort by reducing jolt, translating into better controllability and less operator fatigue.

■ SMALLER FOOTPRINT, GREATER CAPACITY

Ideal for compact operating conditions, Hyster® H300HD₂S and H330HD₂S models are available with all of the features of the standard wheelbase models including masts, carriages and fork options.

- 30,000 lbs. of lifting capacity available on the H300HD₂S and 33,000 lbs. of lifting capacity available on the H330HD₂S available, both with outstanding turning radius (OTR).
- 114" short wheelbase offers compact size with excellent maneuverability.
- Cummins QSB 6.7L Tier 4 Final engine paired with a 3-speed powershift ZF WG-161 transmission for good fuel economy.
- Proportional viscous cooling fan, part of the standard on-demand cooling system, draws power only when cooling is required.
- Additional maneuvering capability has been engineered without compromise in fuel tank volume, hydraulic tank volumes, travel speeds or key performance characteristics.
- The fuel tanks have been engineered with 20% more volume for less frequent fill-ups.



A new addition to the H190-360HD₂ family of trucks, the H210-48HD, H230-48HD and H250-48HD models provide 21,000 lbs., 23,000 lbs. and 25,000 lbs. of lifting capacity at a 48" load center. These trucks are engineered for long load centers, wide loads and heavy duty-cycle conditions for which traditional 24" load center models are less suited.

The same durable mast channel design, greaseable load rollers, stub shafts and chain anchors ensure a heavy duty and robust front end for the most unusual loads in heavy duty applications.

HYSTER TRACKER - WIRELESS ASSET MANAGEMENT

Take your fleet operation to the next level with wireless asset management from Hyster. Hyster Tracker provides a scalable solution for fleets. From monitoring truck utilization to limiting operator access, Hyster Tracker allows you to track your fleet at your fingertips.



TRACKER

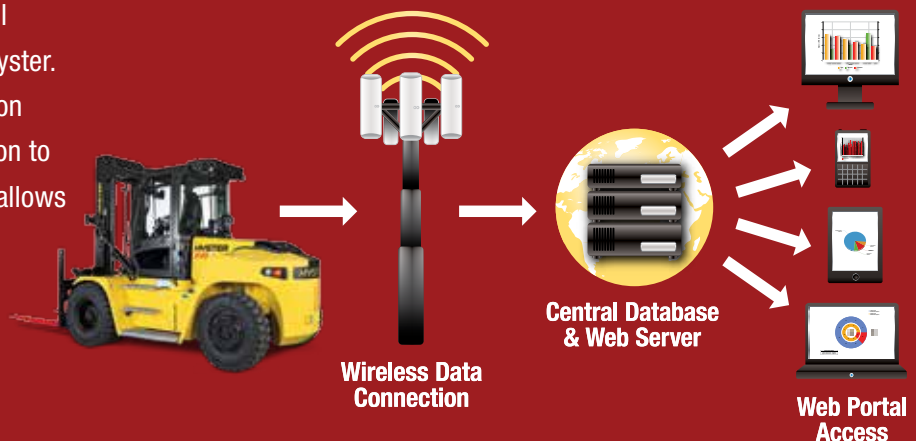

INNOVATIVE TRUCKS ENGINEERED TO MEET THE MOST DEMANDING APPLICATIONS

For more than 80 years, Hyster has been conquering the world's most demanding applications. In the 1920's Hyster started as a manufacturer of lifting machines used in the rigorous logging industry of the United States' Pacific Northwest. A few years later the first forklift trucks were invented and the Hyster® brand quickly gained its reputation for rugged quality. Hyster® lift trucks are designed to lower your cost of operations. Every truck we make — gasoline, LPG, diesel and electric — is purpose-built to excel in its application. Every truck is also backed by an unmatched network of specialists.



Dealer Network — Through our Dealer Network, we can offer the expertise of fleet managers, parts suppliers, capital procurement specialists and trainers. Carefully chosen dealers — and the people they employ — fully understand customer applications, assist in selecting the right lift truck and provide fast, reliable support after the sale.



Hyster Fleet Services — Even if you operate other brands, we can manage your maintenance and replacement plan. We can offer complete fleet analysis, fleet history summary and a cost-effective proposal for replacement and scheduled maintenance.



Parts — With genuine Hyster® replacement parts and UNISOURCE™ parts for all makes of lift trucks, we are your one-stop source for lift truck parts. In fact, we offer more than 7 million part number crosses for most brands of materials handling and other in-plant mobile equipment.



Rental Products — When leasing or buying isn't a practical option, we have access to more than 14,000 units for short- and long-term rental. We'll help you maintain output in a cost-effective manner.



Hyster Capital — We can arrange solutions for special financing requirements, taking the difficulties out of buying the equipment you need. Whether you purchase or lease a new or used lift truck, Hyster Capital offers superior service and competitive rates.



Special Products Engineering Department (SPED) — Different materials require different handling. That's why we can work with you to customize your lift trucks. From strobe lights to specially made forks, SPED has the tools to help you get the job done right.



Operator Training — Proper education in operating lift trucks minimizes the risk of injuries due to accidents while increasing productivity. Hyster offers OSHA-compliant materials that support the training of qualified operators.



Service — Your local Hyster® dealer offers a flexible, customized and comprehensive maintenance plan based on each lift truck's application, make, model and operation environment. Hyster service programs offer scheduled inspections and maintenance, and when you need immediate service on a fleet or single truck, your local dealer offers quick, responsive service dispatched to your location.





Hyster Company
P.O. Box 7006
Greenville, North Carolina
27835-7006
Part No. H190-360HD2/B
7/2016 Litho in U.S.A.

Visit us online at www.hyster.com or call us at 1-800-HYSTER-1.

Hyster, , and STRONG PARTNERS. TOUGH TRUCKS. are registered trademarks in the United States and certain other jurisdictions. Hyster products are subject to change without notice. Cummins, AxleTech, Sy-Klone and ZF are registered trademarks of their respective companies. UNISOURCE is a trademark of Hyster Company.

All trucks shown with optional equipment. ©2016 Hyster Company. All rights reserved.